



GLOBAL
MACHINE TECHNOLOGY



THE SILK SX012 FLANGE FACING MACHINE



Lightweight, portable, flange facing, grooving and weld preparation machine designed to machine full faced, raised face and grooved flanges from 0-12" (0-305mm) diameter.

FEATURES

- Automatic feed rates
- Externally mounted
- Cuts ring joint, raised face, lens ring, and hub profile seats
- Various machining kits
- Multiple surface finishes

MACHINE DESCRIPTION

The Silk SX012 rotary machining center is constructed from the highest quality materials. It is designed to give machine shop accuracy combined with portability and ease of handling on flanges from 0-12" (0-305mm) diameter.

Four separate adjustable clamp blocks are provided which may be positioned on the base ring to suit the size of the flange being machined. The clamp blocks are secured by two cap screws. The machine is locked in position and centered relative to the flanges using the fine adjustment screws on the clamp blocks. Packing pieces are provided for installation between the base ring assembly and the clamps to increase the clearance between the machine and flange face.

The machine is driven by two 0.85hp pneumatic motors, which are mounted directly to the drive and bearing assembly, and are quickly detachable. The drive and bearing are mounted on the base ring assembly and provide the drive for the saddle via a spur ring gear arrangement.

The saddle is mounted on the drive and bearing assembly and provides a rigid structure to which the toolpost is fixed. Input to the saddle is derived from the drive and bearing assembly, internal gear arrangement, and saddle pick-up gear. The saddle and support bearing rotate around the internal gear in a planetary motion. Toolpost traverse in and out is provided by a leadscrew which is driven by a saddle gear train. Traverse is engaged by the feed selector arm. The machine can achieve cuts to a maximum depth of 0.079" (2mm) without flanged holes and 0.039" (1mm) with flanged holes.

The SX012 also houses many bolt-on machining kits such as Hub Profile kit, Lens Ring kit, V-Groove Measuring kit, and AX boring bar kits.

This machine like other Silk manufactured goods are conducted in strict conformance to the ISO 9001 quality system.

Table of Surfacing Feeds

Gearbox	Feed (in)	Feed (mm)
In	0.032	0.81
Out	0.008	0.20
Hand Held	0.002	0.05

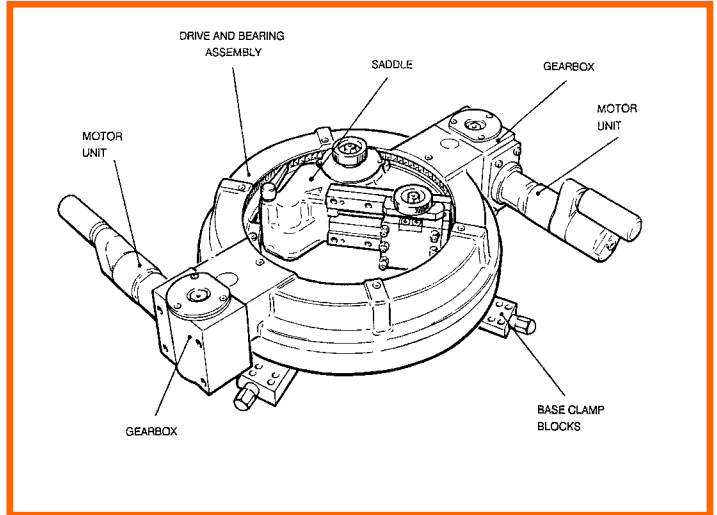

Specifications

Principal Dimensions

Height	5-1/8" (130mm)
Rotational Diameter	12" (305mm)
Maximum Swing	12" (305mm)
Minimum Swing	0" (0mm)
Toolpost Travel	1-5/8" (38mm)
Overall Diameter	24" (610mm)

Weights

Nett Weight	110 lbs. (50 Kg)
Total Shipping Weight	187 lbs. (85 Kg)

Case Dimensions

Length	32" (800mm)
Height	17" (430mm)
Width	28" (720mm)

Flange Information

Gripping Range	4" (102mm) Min. 12" (305mm) Max.
Flange Range	
ANSI Class 150 / 250	1" - 6" (25mm - 150mm)
ANSI Class 600 / 900	1" - 4" (25mm - 101mm)
ANSI Class 1500 / 2500	1" - 3" (25mm - 76mm)

General Information

Drive Motor	(2) - 0.85hp (0.66 kw)
Min. Air Requirements	80PSI @ 80CFM (5 bar @ 2.2 m ³ /min.)
Drive Motor Output	1600RPM
Final Rotation Speed	33Rpm

For further details contact:



11932 Brittmoore Park Drive, Houston, TX 77041
Tel. 832-467-4040 Watts. 800-516-9626
Fax. 832-467-4240