



GLOBAL

MACHINE TECHNOLOGY



THE SILK HD400 PORTABLE DRILLING MACHINE



Portable drilling machine is a compact, lightweight, portable drill used in many on-site applications. Ideal for repetitive drilling and stud removal, this machine can drill up to 10" (250mm) diameter holes dependant on material and depth of cut. Standard stroke length is 10" (250mm) but extended versions are available to 20" (500mm).

FEATURES

- Automatic down feed
- Quick release drill retrieval
- Variable spindle speeds
- No. 5 Morse Taper

MACHINE DESCRIPTION

The Silk HD400 Drill incorporates in its design a versatile mounting base allowing mounting plates to be readily designed to enable work to be carried out quickly and accurately.

The machine consists of a drive and gearbox, four rigid pillars and the mounting base. The spindle incorporates a standard No. 5 Morse taper to run tooling such as HSS twist drills, trepanning cutters, and Super drills. Silk recommends the ladder type of tooling for diameters in the 2"- 10" (50 – 254mm) range.

The drive motors are easily interchanged, along with the availability of special tooling adapters allowing for the quick and simple selection of the correct tooling and speeds.

The base, in addition to the quick release keyhole mounting has a location spigot that enables the drill to be removed and replaced without losing position. The spigot sleeve also allows for optional drill bushes to be fitted to control the drill when starting on radial or uneven faces.

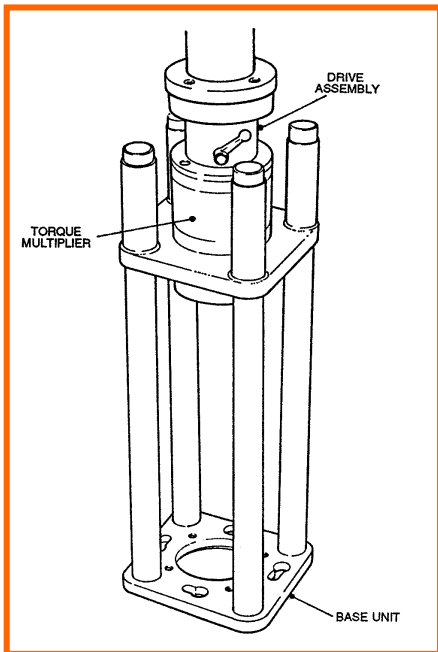
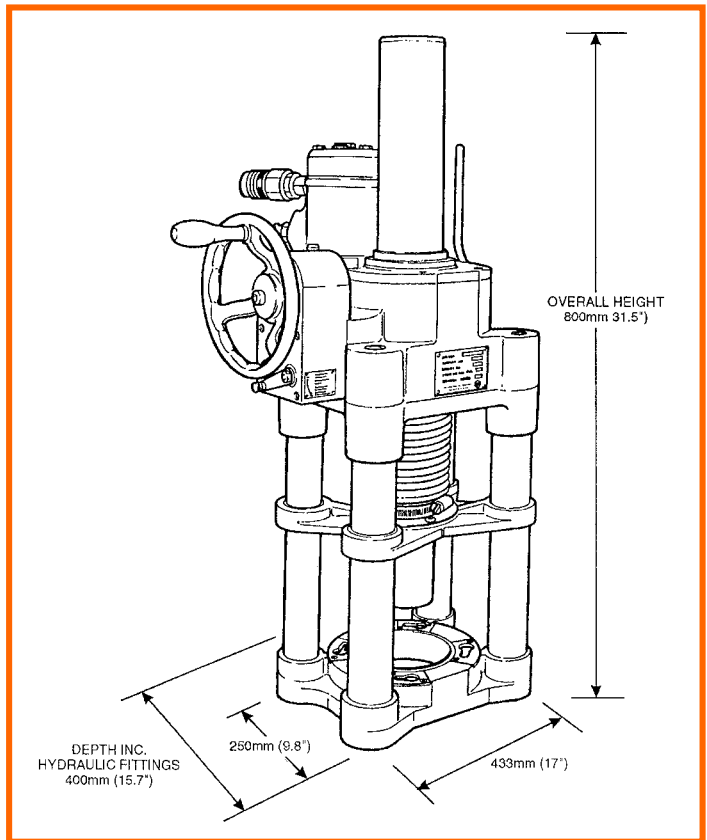

HT400 Tapping Machine

This machine like other Silk manufactured goods are conducted in strict conformance to the ISO 9001 quality system.

Specifications

Weight of drill	125lbs. (57kg)
Shipping weight	250lbs. (118kg)
Case dimensions	45" x 23" x 22" 1150mm x 590mm x 570mm
Spindle speeds	OMP400 (67 RPM) OMP 160 (168 RPM)
Spindle feed rates	0.004" (0.10mm) / rev
Spindle	No.5 MT with a 3/8" BSP for air or coolant connection. No.4MT adapter for smaller twist drills.
Spindle stroke (HD400)	10" (250mm)
Extended stroke (HDE400)	20" (500mm) maximum
Hydraulic requirements	1500 PSI @ 13.2 GPM 100 Bar @ 60 LPM
Optional tapping unit	HT400 – 3 1/2" (89mm) to 6" (152mm) tap capabilities

For further details contact:



11932 Brittmoore Park Drive, Houston, TX 77041
Tel. 832-467-4040 Watts. 800-516-9626
Fax. 832-467-4240