



SILK ACCESSORY ITEMS FOR MILLING, DRILLING, AND TAPPING APPLICATIONS



GMT1030 SINGLE FLOW POWER PACK

FEATURES

- Cutting tools
- Hydraulic Units

HYDRAULIC UNITS

Global Machine Technology single and dual flow power packs are designed for multiple field service applications. Units are designed to run one or two machines at one time and conform with the appropriate flow rates and pressure requirements needed to run Silk portable machine tools. The units are totally portable and come complete with hydraulic hoses, electrical box, pendant control, and steel frame for durability. There are two standard units for running Silk drills and milling machines as well as custom design.

Specifications

	GMT1030 (Single flow)	GMT1040 (Dual flow)
Flow Rates	13.2gpm @ 1,500psi	13.2gpm @ 1,500psi 4.4gpm @ 1,030psi
Remote Pendant	(1) infinitely variable speed and direction control	(2) infinitely variable speed and direction control
Motor Type	15hp 440/ 3 phase	15hp 440/ 3 phase
Reservoir	30Gallon	40 Gallon
Weight / Dims.	300 lbs. 60"x 36"x 36"	700 lbs. 72"x 45"x 45"



SUPERDRILLS

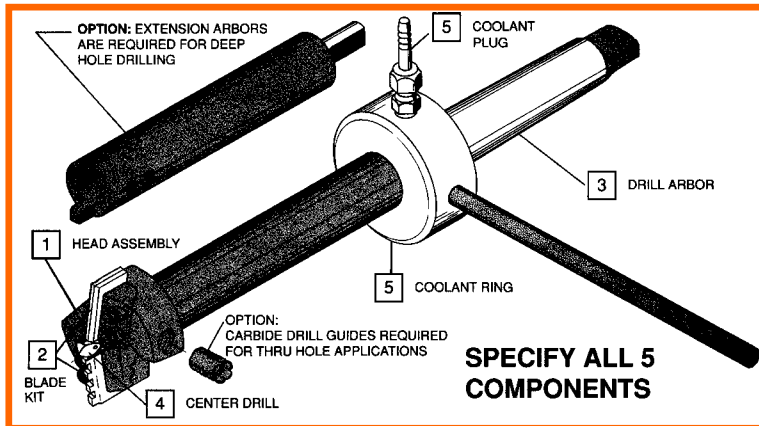

Superdrills are a fast and efficient way to drill large diameter holes. Diameters from 2" - 10" are standard for this product which utilizes a built in pilot and insert tooling for rough and finishing cuts. Additional features such as coolant rings and extended arbors make this a very useful tool for the HD100 and HD400 portable drilling units for stud removal and general hole drilling.

For further details contact:



11932 Brittmoore Park Drive, Houston, TX 77041
Tel. 832-467-4040 Watts. 800-516-9626
Fax. 832-467-4240