



## ACCESSORY KITS FOR FXB630, AX1445, AND AX2872 FLANGE FACING MACHINES



Complete bolt-on accessories like the Ring Type Joint Measuring and Machining kits are used in conjunction with one another to refurbish RTJ flanges.

The pre-set 23° toolpost will cut a RTJ and the measuring kit will accurately check the depth and width of the joint upon completion. Other bolt-on kits are the tube sheet mounting and back facing kits as well as extended tool posts and mini milling kits.

### FEATURES

- Pre-set tools
- Extreme accuracy
- Heat exchanger repair
- Interchangeability

## MACHINE DESCRIPTION

The FXB630, AX1445, and AX2872 flange facing machines are ideal for machining heat exchanger tube bundle gaskets. The machines can be mounted in the bundle I.D. or directly to the tube sheet (see figure 3).

Figure 1 and 2 show the different orientations of the toolpost for machining frontface and rearface gasket areas. The 90° extension is easily attached to the toolpost carriage of the existing machine where automatic feeds drive the radial surface requirements.

Figure 3 shows the tubesheet mounting kit which utilizes a mounting plate, expandable tube plugs and mounting brackets. The machine turntable can be bolted directly to the mounting plate for refurbishing gasket surfaces.

An optional extra for the AX2872 is an O.D. mounting kit. This kit uses additional leg mounts bolted perpendicular to the existing base mount arrangement. Tapings located on the underside of the AX2872 allow for air hook-up when machine is inverted.

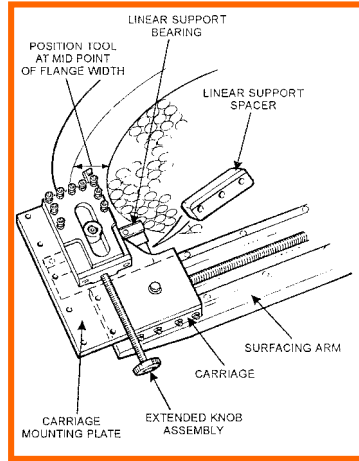

Figure 1  
Frontface tubesheet machining arm configuration

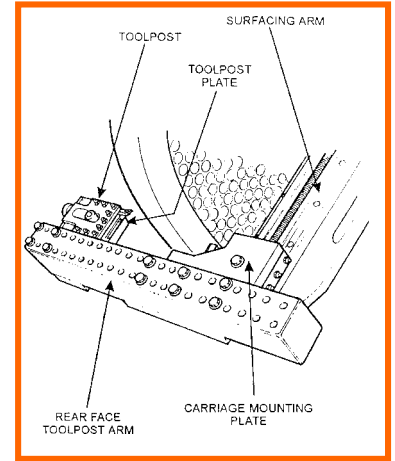

Figure 2  
Rear tubesheet machining arm configuration



Extended Toolpost

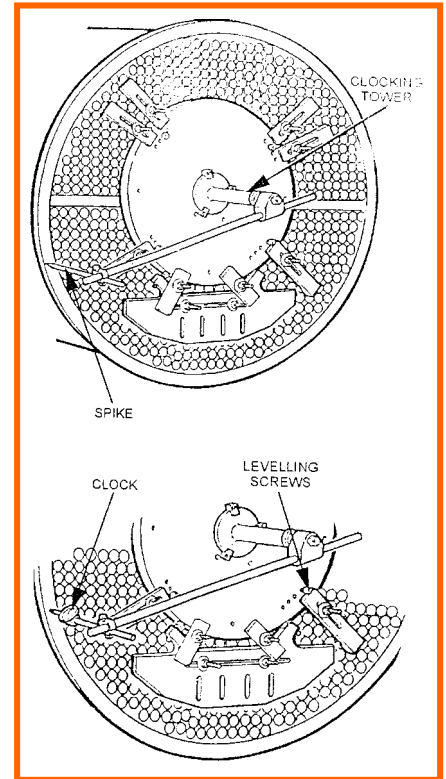

Figure 3  
Tubesheet mounting kit

For further details contact:



11932 Brittmoore Park Drive, Houston, TX 77041  
Tel. 832-467-4040 Watts. 800-516-9626  
Fax. 832-467-4240