



GLOBAL

MACHINE TECHNOLOGY



THE SILK AXLB124 LINE BORING MACHINE

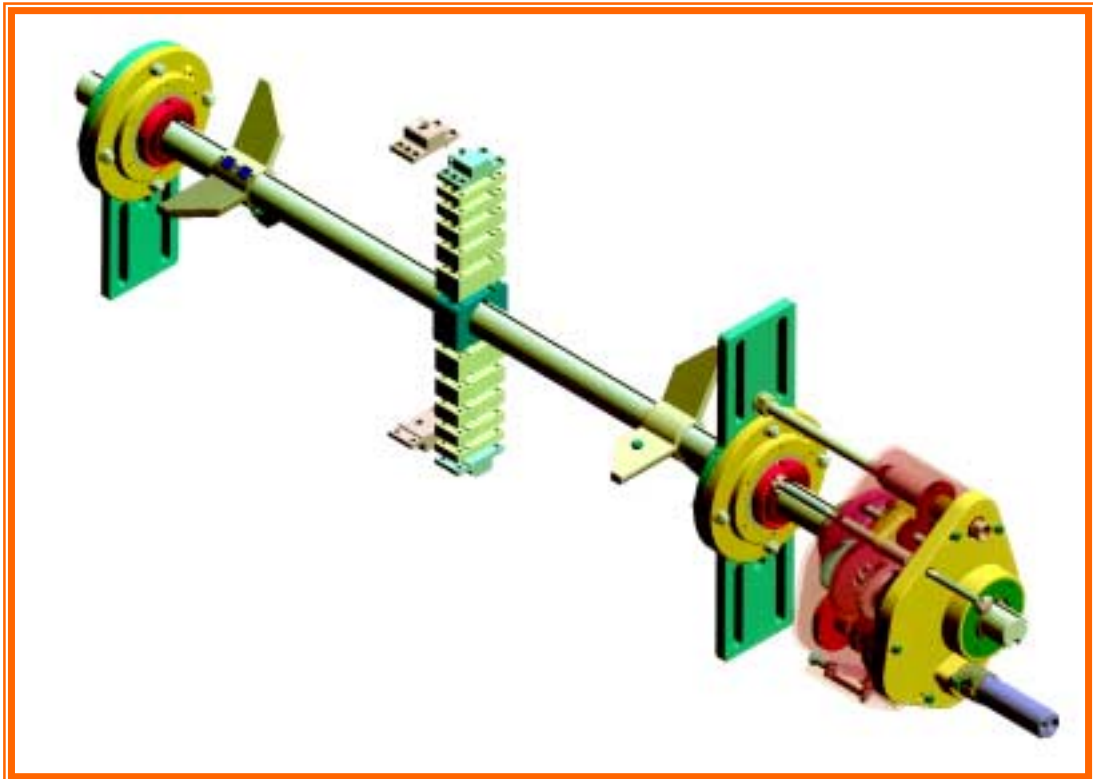

Designed to re-machine bores from 1" (25mm) to 24" (610mm) with gear driven accuracy. Multiple bars and tool set ups give a wide machining range.

FEATURES

- Pre-set cutting diameters
- Extreme accuracy
- Quick return tool retrieval
- Multiple bars
- Rigid set-up

AXLB124

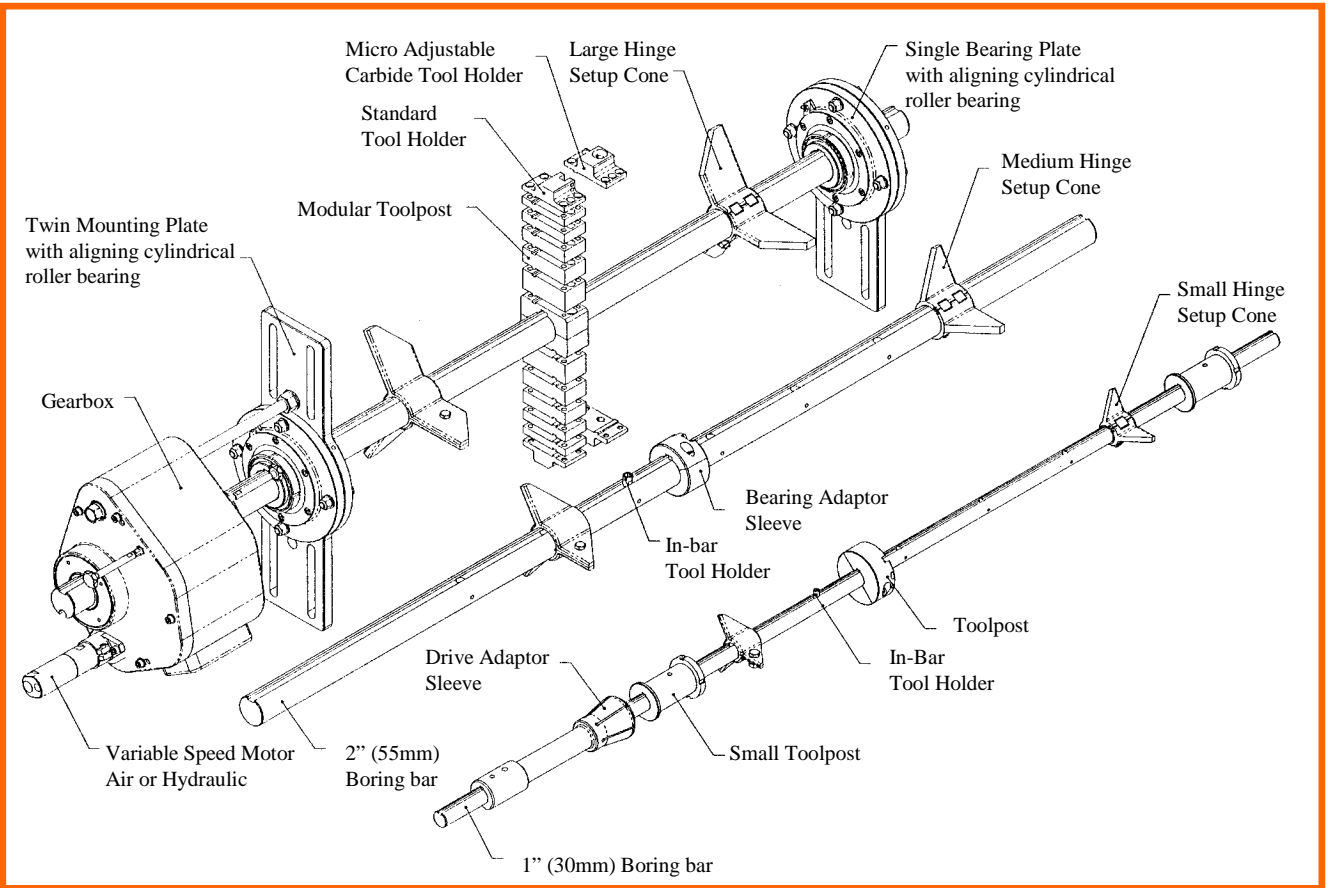

Specifications

Boring Bar Range:

1" (30mm) diameter bar:

In-bar tooling diameters 1.4" (36mm) to 2.6 (66mm)
 Small toolpost diameters 2.6" (66mm) to 4.1" (104mm)

Requirements:

Air (95Cfm @ 90psi) Hydraulic (13Gpm @ 1600psi)

2" (55mm) diameter bar :

In-bar tooling diameter 2.4" (61mm) to 3.9" (100mm)
 Small toolpost diameters 3.9" (100mm) to 5.9" (150mm)
 Modular toolpost diameters 5.9" (100mm) to 13.7" (350mm)
 Optional Extended toolpost 13.7" (350mm) to 24" (610mm)

Boring Bar Lengths:

1" (30mm) bar = 78.7" (2000mm)
 2" (55mm) bar = 78.7" (2000mm)

Gearbox:

Direct drive = 0.080" (2mm) / Rev
 Feed 1 = 0.033" (0.85mm) / Rev
 Feed 2 = 0.016" (0.40mm) / Rev
 Feed 3 = 0.008" (0.20mm) / Rev
 Feed 4 = 0.004" (0.10mm) / Rev

For further details contact::



11932 Brittmoore Park Drive, Houston, TX 77041
 Tel. 832-467-4040 Watts. 800-516-9626
 Fax. 832-467-4240