



SILK AX BORING BAR 100 & 400



AXBB100

The Silk AXBB100 boring bar is designed to bore and face without the use of a steady for a number of applications. Ideal for facing recessed seat faces the AXBB100 is also very good at machining bores in valves, pumps, and compressor cylinders.

The AXBB is driven and positioned with the use of the SX012 or AX024 rotary machining center. The automatic down feed is engaged by the spur ring gear of the machining center and the radial feed incorporates a reduction gear box, engaged by holding the autofeed gearbox knob. There are two built in feed rates for bore surfaces and one fixed rate for radial surfaces.

A digital readout attached to both boring bar types give accurate readout to 0.001" which helps out in set up and boring operations.

The Silk AXBB400 Boring Bar is very similar to its brother the AXBB100 except for boring lengths and the use of a steady. Ideal for machining Governor valves, it has applications for refurbishing deep recessed seat faces down to 40" and boring capabilities out to 16" diameters.



AXBB400

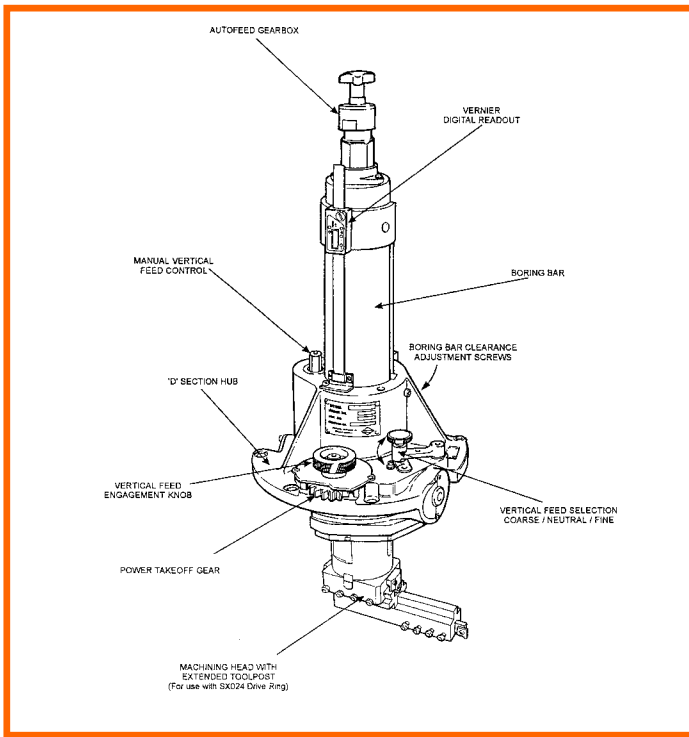

Specifications - AXBB 100

Bar length (including gear box)	36" (914mm)
Bar diameter	3-3/4" (95mm)
Boring machine range	2-20" (51-508mm)
Facing machine range (diam.)	4" - 11" (102 - 275mm)
Extended tool range (diam.)	11" - 18" (275 - 457mm)
Feed rate (radial)	0.005" (0.127mm) / rev.
Feed rate (axial)	
Course	0.016" (0.406mm) / rev.
Fine	0.005" (0.127mm) / rev.
Weight of boring bar	110lbs. (50kgs)
Total shipping weight	244lbs. (111kgs)

Drive Ring

Review technical specification sheet for the Silk SX012 and AX024 O.D. mount ring machines.

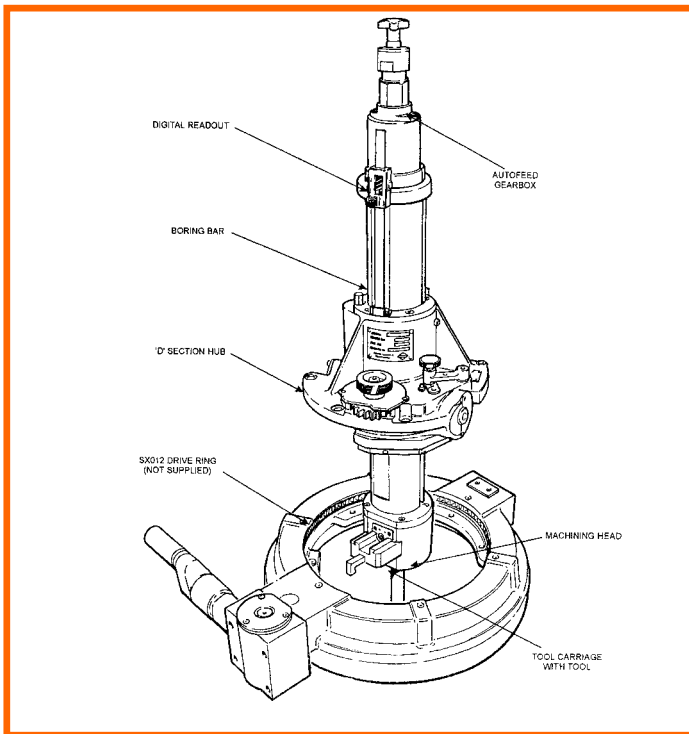

Specifications - AXBB 400

Bar length (including gear box)	40" (1000mm)
Bar diameter	3-3/4" (95mm)
Boring machine range	0-40" (0-275mm)
Facing machine range (diam.)	4" - 11" (102 - 275mm)
Extended tool range (diam.)	11" - 16" (275 - 392mm)
Feed rate (radial)	0.005" (0.127mm) / rev.
Feed rate (axial)	
Course	0.016" (0.406mm) / rev.
Fine	0.005" (0.127mm) / rev.
Weight of boring bar	176lbs. (80kgs)
Total shipping weight	250lbs. (113kgs)

Drive Ring

Review technical specification sheet for the Silk SX012 and AX024 O.D. mount ring machines.

For further details contact:



11932 Brittmoore Park Drive, Houston, TX 77041
 Tel. 832-467-4040 Watts. 800-516-9626
 Fax. 832-467-4240